



**JINDAL'S**

**South Asia's Largest  
Power Control Company**

**Stabilizers • Rectifiers • Transformers**

**JINDAL'S** founded in 1967, is a well known group of companies which specialize in the design, engineering & manufacture of varied energy efficient electrical equipment. **JINDAL'S** is the pioneer & the undisputed market leader in the field of industrial voltage stabilizers and Rectifiers in South Asia, since last four decades. The group is widely recognized for its unmatched value system of quality, Service and relentless pursuit for excellence.

Our diverse product range covers Industrial Automatic Voltage Controllers, Silicon Power Rectifiers, Variable Voltage Transformers, Isolation Transformer & Other special purpose transformers.

The **JINDAL'S** group operates from six factory complexes in Haryana & Punjab in India. It is reputed for its customer-centric approach and has the largest client base and service network in the industry.

**JINDAL'S** pioneering research and passion for quality has helped it attain a dominant position not only in the Indian sub-continent, but also in several export markets, such as Bahrain, Bangladesh, Bhutan, Brazil, Congo, Ghana, Guinea, Indonesia, Ivory Coast, Kenya, Kuwait, Malaysia, Mali, Mexico, Nepal, Nigeria, Philippines, South Africa, Sri Lanka, Tanzania, Uae, Uganda, Uzbekistan, Vietnam, Zambia

In 2012, **JINDAL'S** also forayed into manufacture of electronic components, such as LED Lamps & Lighting, EMI Filters, Mica Capacitors etc., for use in Defence & Aerospace sectors. It has a **Technology Teaming Arrangement** with **Oxley Developments Company Ltd.** of **UK** for manufacture of these components, which are then sold to leading defence sector companies within India and also re-exported back to Oxley for distribution worldwide.

Recently, **JINDAL'S** has launched high capacity, 100% Natural Air Cooled Stabilizers, **FIRST** of its kind in **INDIA**, in **Collaboration** with **IREM SpA** of **Italy**, which is one of the world's largest manufacturer of air-cooled stabilizers since over six decades.



Factory Site

**35+**

Countries across  
5 Continents

**174+**

Sales & Service Centres  
across India & Abroad

**25000+**

Installations across industry  
spectrum

# Driven by Core Values

**JINDAL'S**

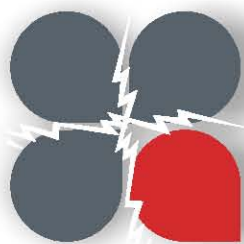

**Innovation  
& Continuous  
Improvement**



**Customer  
Satisfaction**



**People**

## **JINDAL'S VISION**

**Where values combine with commitment  
to offer Energy Efficient Products and  
Solutions**

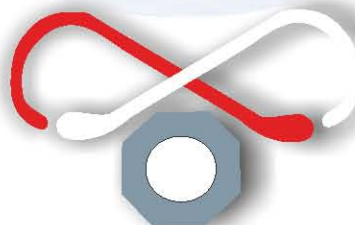

**Performance  
with Integrity**

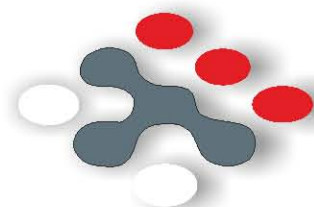

**Customer - driven  
Quality**



**Management by  
Facts and Data**



## “A commitment of flawlessness”

At **JINDAL'S**, we continually strive to improve the quality, skill & competency of the products & services we supply and it is our endeavour to supply in strict accordance with our contractual, statutory and regulatory requirements.

We follow rigorous quality control across different stages of manufacturing through a dedicated quality control team. **JINDAL'S** is the only company in the industry to have its equipments tested & certified for its widely acclaimed Efficiency, by nationally reputed testing agencies such as ERTL, National Physical Laboratory and many other independent energy auditors.

We have state-of-the-art testing facilities at all our manufacturing units and each of our equipments undergoes the following tests to ensure flawless delivery to our customers:

### Routine Tests

- Insulation Resistance
- High Voltage tolerance test
- Winding Resistance measurement
- Measurement of zero load current & losses
- Measurement of impedance voltage & load losses
- Megger test
- Induced Voltage tolerance test
- Test on oil for BDV, moisture etc.
- Measurement of acoustic noise level
- Range test

### Type Tests

- Temperature Rise test
- Short Circuit test

### Special Tests

- These can be conducted as per specific requirements



**JINDAL'S** is the pioneer & the largest manufacturer in South Asia in the field of industrial power control equipments since 1967. Our products are reputed for their robust design & rugged construction. **JINDAL'S** equipments are designed for 100% continuous duty cycle and for heavy-duty industrial applications.

**JINDAL'S** equipments are equipped with Vertical Rolling Contact Type **ON LOAD Voltage Regulators**, which is actually our forte across the sub-continent.

**JINDAL'S** range of products find wide applications across the industry spectrum.

**AUTOMATIC VOLTAGE CONTROLLERS  
OR INDUSTRIAL SERVO VOLTAGE STABILIZERS:  
30 to 5000 KVA capacity**



**SILICON POWER RECTIFIERS:  
0 to 1000 Volts D.C., and Up to 30000 Amps**



**SPECIAL PURPOSE TRANSFORMERS:  
Isolation Transformers  
Variable Voltage Transformers  
Step-Up & Step-Down Transformers  
Balancing Transformers  
Furnace Transformers**



# Automatic Voltage Controllers

**JINDAL'S Automatic Voltage Controllers** are designed to reduce the failure rate of your equipment, optimize the use of power & save energy. Our equipments are suitable for any kind of heavy - duty, industrial load.



Input Voltage Variation	Possible % Reduction in Breakdown		Possible % Power Saving	
	Motors Below 10 HP	Lighting load	Motors Below 10 HP	Lighting load
380-400 V	No Reduction and No AVC required		No Power saving and No AVC required	
400-420 V	5%	10%	3%	5%
420-440 V	10%	20%	5%	10%
440-460 V	20%	40%	7%	20%
460-480 V	40%	80%	10%	30%



## **BENEFITS**

- ⌘ Up to 80% reduction in failure rate of electrical equipment
- ⌘ Energy saving up to 10% (up to 30% on lighting load)
- ⌘ Reduction in MDI
- ⌘ Improvement in Power factor
- ⌘ Uniform quality of end product
- ⌘ Improve Productivity of the plant



## **PAY-BACK PERIOD:**

Owing to its high efficiency & associated benefits, the pay-back period for the cost of **JINDAL'S** stabilizers is generally between 6 to 12 months. And it saves you significant costs in subsequent years through its life.

## **GENERAL TREND OF VOLTAGE DURING DAY TIME**

340V-400V	400V-440V	340V-400V	400V-430V	400V-470V	400V-450V
09:00 HRS. - 12:00 HRS.	12:00 HRS. - 14:00 HRS. Lunch Hours	14:00 HRS. - 18:00 HRS.	18:00 HRS. - 22:00 HRS. Peak Hours Restriction	22:00 HRS. - 05:00 HRS.	05:00 HRS. - 09:00 HRS.

## SPECIFICATIONS

**JINDAL'S** Servo Voltage Stabilizers are available in a wide range and various models, incapacities ranging from 30 KVA to 5000 KVA. The standard models conform to the following specifications:

Input Voltage (Volts)	350 - 450V, 340 - 460V, 330 - 470V, 320 - 460V, 300 - 460V,
Efficiency ( Approx.)	~99.5% ~99% >98.7% ~98.5% >98 %
Output Voltage	400V ± 1%, 3- Phase, 50 Hz
Cooling	Natural Oil Cooled (upto 5000 KVA) / Air Cooled (upto 4750 KVA)
Type	Indoor / Outdoor
Temperature Rise (Max)	Designed for 30-35°C above ambient as on top of oil full load (against IEC standard of 45°C)
Mounting	Uni-directional wheels
Correction Rate	6-15 V/ Second (Up to 500 KVA) and 3-6 V/Second ( Above 500 KVA)
Wave Form Distortion	Virtually Nil
Duty Cycle	100% Continuous
Reference Standard	IEC 60076

**Note:** Non-Standard Input and output models are available against specific requirements.

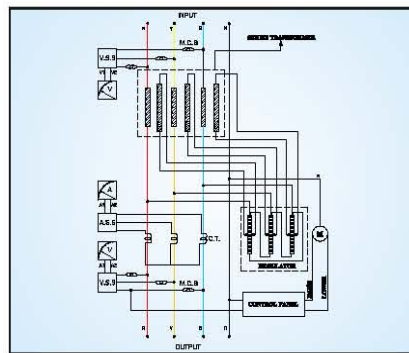

Basic Circuit



Inner view of 2000 KVA Stabilizer

## APPLICATIONS

Cement Plants	Rolling Mills	Rubber Industries	Distilleries & Beverages
Flour Mills	Textile Mills	Tea Estates	Hospitals
Engineering Units	Paper Mills	Food Processing Units	Nursing Homes
Pharmaceutical Units	Tube Mills	Oil & Vanaspati Plant	Hotels & Clubs
Cold Storage Units	Rice Shellers	Footwear & Leather Units	High Rise Buildings

# *S*ilicon Power Rectifiers

**JINDAL'S** Rectifiers are designed for continuous rated current with adequate margin of safety. These are capable of working at 100% load factor.

## ADVANTAGES

- ✧ Step-less On-Load Voltage Regulator
- ✧ Designed for 100% continuous load
- ✧ Nil Waveform distortion
- ✧ High Efficiency of up to 97%
- ✧ Virtually zero maintenance

## APPLICATIONS

- ✧ Electroplating / Electro-polishing
- ✧ Metal mining, refining & extraction
- ✧ Furnace & Heating systems
- ✧ Metal & glass melting
- ✧ Effluent Treatment plants
- ✧ Production of Hydrogen gas
- ✧ Production of Chlorine gas
- ✧ Variable speed drives
- ✧ Anodizing plants
- ✧ Etching
- ✧ Electrophoresis coating plants
- ✧ Heating Lehrs
- ✧ Annealing processes
- ✧ Chemical electrolytic processes





## SPECIFICATIONS

The standard model conforms to the following specifications:

- **Output Voltage:** From zero to max. rated D.C. voltage (upto 1000 Volts)
- **Output Current:** From zero to max. rated D.C. current (upto 30000 Amps)
- **Input Voltage:** 415V, 3-phase, 50 Hz, A.C.
- **Natural Oil cooled**
- **Modes of Operation : Manual Control**
  - Electrical with the help of push buttons
  - Mechanical with the help of T-Handle
- **Ripple Content: Less than 5%**
  - Model with 1% ripple available as optional feature
- **Efficiency :**

12 V Rectifier:	86%
24 V Rectifier:	90%
100 V Rectifier:	94%
200 V Rectifier:	96%
250 V and above:	>97%

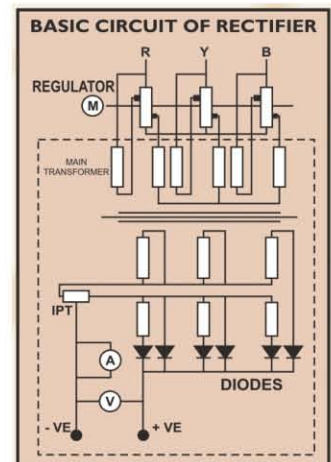

Note: Non-standard models are also available against specific requirements.

## OPTIONAL FEATURES:

- Constant Voltage Controller (CVC)
- Constant Current Controller (CCC)
- D.C. Overload Trip system
- Zero Run Down system
- Programmable Ramping Arrangement
- Signal Isolators to enable automation / PLC compatibility



## JINDAL'S VOLTAGE REGULATING TRANSFORMERS

The **JINDAL'S** Linear Voltage Regulating Transformer has been designed to meet a wide range of heavy-duty industrial applications as well as for Electricity Supply Utilities. Globally, these have become an established method of control, wherever continuously variable on-load control of voltage and power is needed. These can also be used to control many industrial processes like adjusting temperature, flow speeds, drive speeds, etc. to a pre-set programme.

**JINDAL'S** Voltage Regulating Transformers & Regulating units combine fixed ratio transformers with regulating transformers to extend their rating, versatility and applications. Depending on cooling medium & connection, designs range from low order KVA's to several hundred KVA as a stand alone unit. Using multiple voltage regulators, in combination with fixed ratio transformers, capacity levels are extended into the 5 MVA range.

### APPLICATIONS

The applications for **JINDAL'S** voltage regulating transformers and units fall into two broad basic groups:

- **Maintaining constant output levels** by compensating automatically for variations in supply voltage. Our **Automatic Voltage Controllers** fall in this category, which are installed either along with the main distribution transformer / panel to stabilize the voltage to entire plant, or to individual machines or processes to hold voltage / current/ power / temperature / lighting intensity constant. They are equally suited to A.C. or D.C. applications.
- **Giving a smoothly variable output voltage** for different & continuous heavy-duty industrial processes, wherever voltage has to be smoothly adjusted on load over a wide range of control without effecting the power factor or waveform of the system. Our **Silicon Power Rectifiers** and **A.C. Variable Voltage Transformers** fall in this category.

### CONTROL FEATURES

- **Manual / Mechanical Control:** For the simplest requirement, a "T" handle or Hand-Wheel is provided at a convenient operating height.
- **Motor Control:** with the help of push-button controls through a single phase reversible motor, driving through an internal gear box.
- **Automatic Control:** with help of a Voltage Sensing Relay in case of a voltage stabilizer, and with help of Signal Isolators to facilitate PLC compatibility / automation for Rectifiers & Variable Voltage Transformers



Regulator

## ADVANTAGES

There are many inherent benefits that lead users to choose **JINDAL'S** rolling contact voltage regulating transformers over other conventional technologies:

- **High Efficiency:** More than 99% in average running conditions. This is mainly due to use of heavy sections of copper strips (reducing  $I^2 R$  losses) & the +/- type regulator being partially or fully out of circuit most of the time thereby minimizing copper losses.
- **Virtually Zero Maintenance:** **JINDAL'S** regulators are wound with heavy sections of copper strip & use carbon rollers with life of up to 100,000 meters of track travel (no change required over several years). They require negligible maintenance through their life and their essentially simple, robust construction makes it extremely easy even for an ordinary technician to maintain. The contacts each with current limiting and current carrying paths, revolve while traveling along the coil face and are so designed, that with the correct contact pressure wear & tear is negligible.
- **Undistorted output:** Being a continuously tapped auto transformer design, the **JINDAL'S** regulating transformer is virtually free from waveform distortion.
- **Constant Power Factor:** The low reactance design produces virtually nil power factor deterioration, throughout the whole range of voltage control. The low reactance ensures that changes in load, from zero to full load, have very little effect on the output voltage.
- **Frequency Independent:** Output voltage level is unaffected by frequency variations (within 10%) in the incoming supply.
- **Interference - Free:** **JINDAL'S** regulators present no problems of interference with telephones, radio and TV or electronic equipment.
- **Mechanism:** The use of a chain drive enables the **JINDAL'S** linear regulating transformer to be driven at relatively high speeds, ensures smooth commutation and avoids jamming.
- **Close & Precise Control:** The low inertia of the moving parts, even in the largest sizes enable intricate operating cycles to be followed faithfully and without complications.



**Carbon Roller**

**JINDAL'S** believes in helping its customers achieve the **Lowest Total Cost of Ownership** and endeavours to support its customers throughout the life of their equipments ...even beyond the Guarantee period.

We recognize that any down time of critical equipment and machinery is expensive. Our highly skilled team of service experts, equipped with full range of tools & spares, is spread in a manner to get your equipment back on line, in the shortest possible time. Our service downtimes are the least in the industry, and our service network is the most wide spread. It's a different matter though that **JINDAL'S** equipments rarely require any corrective maintenance.

Our central helpline accepts and resolves your complaints round the clock on all working days .

Our network of more than 400 Authorized Service Engineers / Technicians and Centers is spread across India, Nepal, Bangladesh and Kenya ...and is continuously expanding!

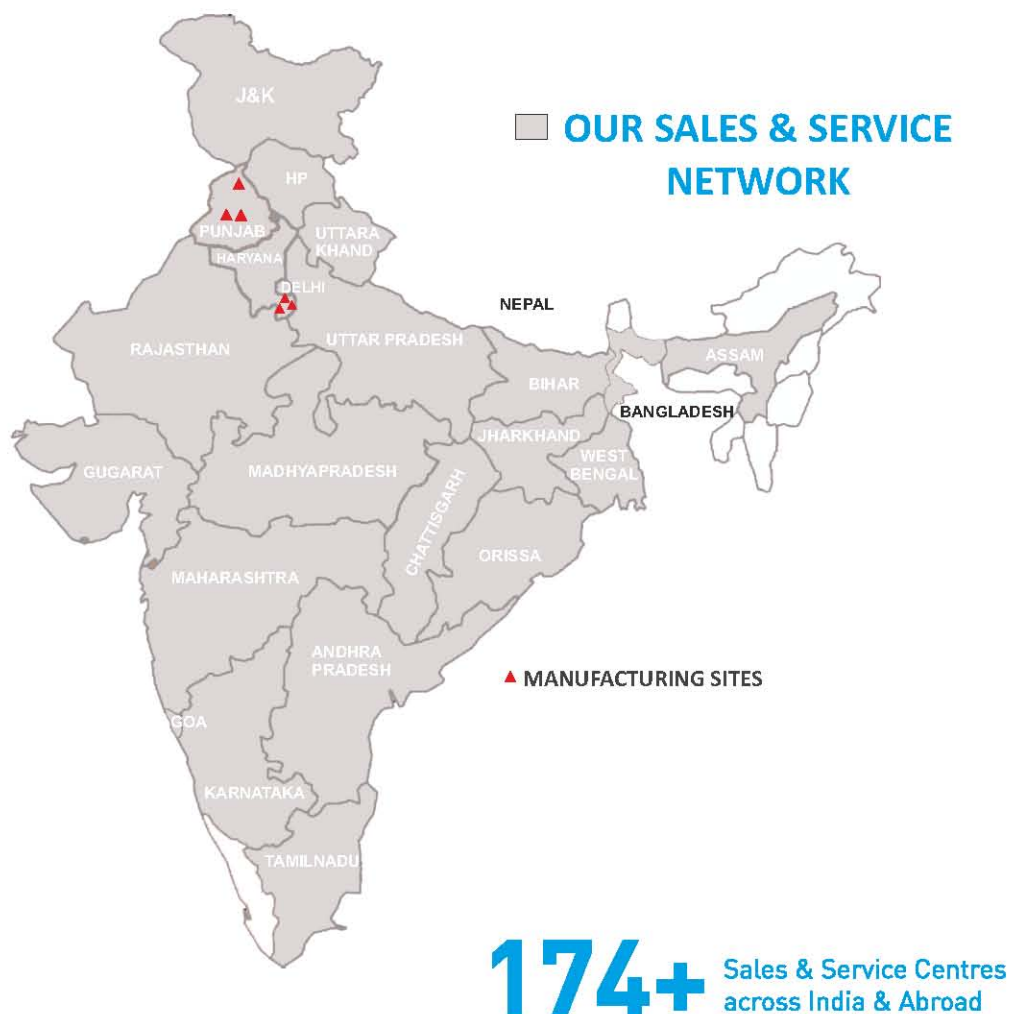

### The **JINDAL'S** Promise

Customer is at the heart of everything that we do at **JINDAL'S**.

When you choose **JINDAL'S**, you are assured of impeccable quality, durability, best-in-class efficiency, extra-long life and trouble-free performance for years, in other words - **Lowest Total Cost of Ownership**. We ensure that your investment in our products works round the clock & pays you back many times over!

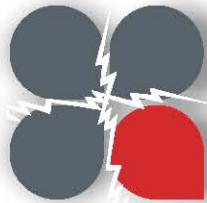

**Green Technology**  
**Best-in-class Efficiency**



**Lowest Total Cost of Ownership**  
**Prompt Service**



**Commitment**

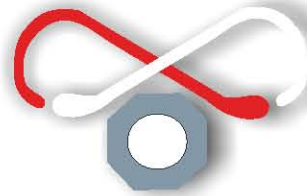

**TRUST -**  
**Maintenance free Performance**  
**Product Life of > 20 Years**



**Efficient Cost Structure**  
**Compact designs - Small Footprint**



**Payback Period**  
**of 6 - 12 months**

**We proudly say that “Our Customers are our best Sales Force”, and indeed so !**

# Our Esteemed Clients

JINDAL'S

ABB

Airtel  
Express Yourself

AREVA

BAJAJ  
Distinctly Ahead

Coca-Cola

Cummins

GENPACT  
Global Business Impact™

GM

HYATT  
HOTELS & RESORTS

HCL

HINDALCO  
ADITYA BIRLA GROUP

HERO  
HONDA

Hindustan Unilever Limited

Infosys®  
POWERED BY INTELLECT  
DRIVEN BY VALUES

ITC  
ITC Limited

!dea™

इंडियनऑयल  
IndianOil

LT

LML

PEPSI

PERFETTI  
van Melle

Parle Agro  
refreshing India

Pfizer

RANBAXY  
LABORATORIES LIMITED

SAMSUNG

TAJ

THERMAX

TATA

UB  
GROUP

vodafone

Whirlpool

भारतीय  
सर्वोच्च न्यायालय  
संविधान संघ



**JINDAL'S**

**SOUTH ASIA'S LARGEST  
POWER CONTROL COMPANY**

**Corporate Marketing:**

Plot # 195 & 163, Sector-24, Faridabad-121 005 (Haryana) INDIA

**Tel:** +91-129-4318001 to 05, 4063165, **Fax:** +91-129-2234165

**Mobile:** +91-9910993162 / 9910993163 / 9910996599

+91-85275499 00 / 11 / 22 / 33 / 44 / 55 / 66 / 77 / 88

**Email :** sales@jindalelectric.in / exports@jindalelectric.in

[www.jindalelectric.in](http://www.jindalelectric.in)



**JINDAL RECTIFIERS**  
Faridabad (India)



**JINDAL ELECTRIC  
& MACHINERY CORP.**  
Ludhiana (India)

**AUTOMATIC VOLTAGE CONTROLLERS | SILICON POWER RECTIFIERS | SPECIAL PURPOSE TRANSFORMERS  
LED LAMPS & LIGHTING | EMI FILTERS & FILTERED CONNECTORS | MICA CAPACITORS**